



7000/8000 SERIES BALL VALVES INSTALLATION - MAINTENANCE MANUAL

USE:

The design features of this valve include three piece construction and a "free floating" ball allowing ease of maintenance without special tools. The ball is not fixed, but is free to move with the line pressure. As a result of this feature, these valves are capable of tight shut-off with flow in either direction regardless of the position of the valve in the line.

The downstream seat, opposite the pressurized side of a closed valve, must carry the load exerted by the line pressure on the ball, while the upstream seat is subject to little load or wear. For this reason, it is sometimes possible to increase useful seat life by turning the valve end-for-end in the pipeline.

1. USE:

The valve should be maintained as part of a preventative maintenance program and in accordance with Flow-Tek's recommended pressure, temperature and corrosion limits to ensure a long service life. During shipment, storage, and in operation, the valve should be fully open or fully closed ("open" is preferred for shipping and storage). Do not use in throttling service without investigating flow and pressure conditions.

WARNING: Before installing this equipment, confirm that it is suitable for the intended service.

The identifications tags describe the maximum allowable service conditions for this product.

Be sure that the installation is protected by appropriate pressure control and safety devices to ensure that acceptable limits are not exceeded.

2. OPERATION:

Operation of the valve is done by turning the handle a 1/4 turn (90 degree turn). CW to close, CCW to open.

A. VALVE OPEN POSITION

The handle is parallel with the pipeline.

B. VALVE IN CLOSED POSITION

The handle is perpendicular to the pipeline.

Valves with actuators should be checked for actuator -valve alignment. Misalignment will result in high operational torque and damage to valve stem and seals.

STEM SEAL ADJUSTMENT:

Stem seal leakage may be corrected without disassembly by tightening the packing gland nut until such leakage stops. If the leakage continues or valve operating torque becomes excessive, the seals are worn and replacement will be necessary.

1. For 1/2" - 2", if slight leakage is noted at stem, straighten lock washer tab, tighten stem nut to flatten Bellville Washers, back stem nut off 1/4 turn, secure lock washer tab.
2. For sizes larger than 2", simply tighten the gland bolts evenly until leak stops. Do not over tighten.

3. GENERAL INFORMATION FOR ON-SITE INSTALLATION:

Before installing the valves, the pipes must be flushed clean of dirt, burrs, and welding residues, or the seats and ball surface will be damaged.

The valve may be installed in any position on the pipeline.

The pipe must be correctly aligned and spaced as to not induce stresses in the valve.

As shipped from the factory, Valves may contain silicone based lubricant. This is for break-in and may be removed by disassembly and solvent washing, if it is objectionable for a particular application.

INSTALLATION OF THREADED END VALVES:

1. The use of a thread sealant is recommended; Use conventional sealant, such as hemp core, Teflon, etc;
2. Apply wrench only on the hex/octagon nearest



the valve end being tightened. Do not tighten by applying torque to the opposite end cap or other valve component. Tightening by using the valve body, handle or the opposite end cap can seriously damage the valve; Use a wrench on both the near end cap and pipe to avoid applying torque to the body through the bolting.

3. In some applications, threaded end valves may be back-welded on site. Use caution. Do not overheat the valve body. Confirm that the end cap bolt holes are aligned with the body screw holes on both ends and that the end caps are parallel and correctly spaced to fit the valve body before re-assembly or back welding. Make up both of the threaded connections normally and then remove the body assembly as described below for weld-end connections before back welding the threaded connection.
4. Do not use the body screws to pull the pipe ends together or into alignment.

INSTALLATION OF WELD-END VALVES (7200, 7300, 8200 & 8300 Series)

Insure that weld procedures are implemented that are compatible with the materials used.

1. Tack weld the valve to the pipe at four points on both end caps.
2. With the valve in open position, (the valve is in the open position when the handle is parallel to the axis of the valve and pipe), loosen all body bolts, take the body out.
3. Turn the handle in the half open position. Remove the seats and body gaskets.
4. Turn handle in closed position and remove ball.
5. Place all removed parts in a clean and secure place.
6. Replace the body and all bolts and tighten them slightly. This operation is very important, so that the body and end caps remain perfectly parallel, thus preventing any leakage at the body joint after welding.
7. Finish welding both end caps onto the pipe.

8. When cool, remove the body, clean end caps, and reassemble per instructions below.
9. Place body between the two end connections; then replace all bolts and cross tighten.
10. (See table 1. Tightening torques for end cap screws).

INSTALLATION OF EXTENDED WELD END VALVE

Insure that weld procedures are implemented that are compatible with the materials used.

1. Butt weld valves with 3 inch or longer extended weld ends do not require disassembly for installation welding.
2. Ensure that ball is in the full open position, and perform normal welding procedures, using care that the valve body does not reach a temperature above 200°F. Use temperature measuring crayons to monitor body temperature if needed.

4. DISASSEMBLY & CLEANING PROCEDURES:

CAUTION: Line must be depressurized before disassembly. Valve should be cycled after draining the system to relieve any pressure trapped in valve cavity. Ball valves can trap pressurized media when closed. Flush line with valve 1/2 open to remove hazardous media. If the valve has been used to control hazardous media, it must be decontaminated before disassembly.

WARNING: DO NOT attempt to remove packing components or any other valve parts while line is under pressure!

CAUTION: Properly support the valve before removing or loosening any body bolts. The larger sizes are heavy and may cause injury if allowed to swing or fall freely.

Remove actuation air and power connections and confirm that there is no stored energy in the actuation such as compressed springs or trapped air before beginning. Stored energy devices can cause serious injury if the energy is released without warning.

DISASSEMBLY FOR STEM AND SEAL SERVICE:

1. It is not necessary to remove the flanges from the



pipeline. Removing any actuation and controls may make service easier.

2. Remove one of the upper body bolts (all but one set of screws for 6" thru 12") and loosen the remaining bolts. The center body will swing out for service, leaving the end caps in place on the pipe ends.
3. To completely remove the valve from the pipeline, remove the remaining upper body bolt and the body will lift free. Gently support the body in a vise to complete the remainder of the disassembly. To avoid damage to the seal surfaces, hold the body horizontally across its diameter, not across the end faces.
4. Remove the seats and end seals.
5. 1/2" thru 2-1/2" sizes; Remove the handle nut and handle. Straighten the tab on the tab washer and remove the lock nut. Remove the tab washer, Belleville washers and gland sleeve.

6. 3" and 4" sizes; Loosen the handle set screw and remove the handle. Remove the snap ring, travel stop, housing bolts and housing. Remove the packing gland bolts, gland, gland sleeve and washers.
7. 6" thru 12" sizes; Loosen the handle junction head set screw and remove the handle assembly. Remove the snap ring, travel stop, housing bolts and housing. Remove the packing gland bolts, gland, gland sleeve and washers.
8. To remove the ball, rotate the stem so the ball is fully closed. Lift the ball from body, using a strap and lift device if necessary. **NOTE: Extreme caution should be taken to avoid damage to the ball.**
9. The stem must be removed from inside the body - a tap on the top of the stem should loosen it. The thrust washer should come out with the stem. Then remove the stem packing.

Disassembly for servicing seats and stem seals may be performed without removing the end flanges from the pipeline. This feature allows the removal of the valve from service without disturbing piping connections.

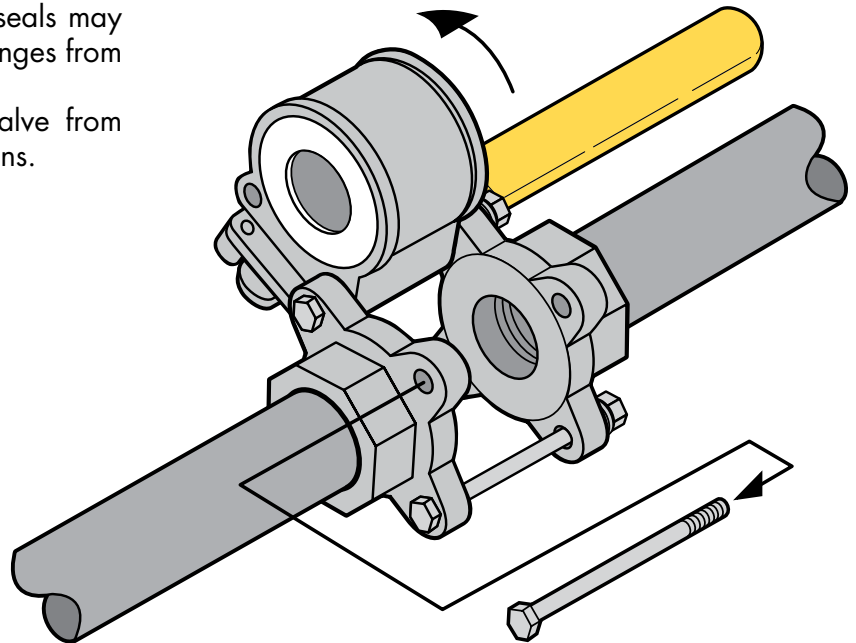



5. VISUAL INSPECTION:

Clean and inspect metal parts. It is not necessary to replace the ball and stem unless the seating surfaces have been damaged by abrasion or corrosion. Replacement of all soft parts is strongly recommended whenever the valve is disassembled for reconditioning. This is the surest protection against subsequent leakage after valve assembly. The replacement parts can be ordered in kit form.

NOTE: The valve may be assembled and operated dry where no lubricants are allowed in the system; however, a light lubrication of mating parts will aid in assembly and reduce initial operating torque. Lubricant used must be compatible with the intended line fluid.

6. RE-ASSEMBLY:

½"-2" VALVE RE-ASSEMBLY PROCEDURES: (refer to page 6)

1. Hold the body horizontally in a vise firmly enough that it will not move but do not crush it.
2. Put washer protector (11A) and thrust washer (12) on valve stem (5) and slide the stem into the stem hole from inside valve body (1);
3. Slide the stem packing components (14) onto the stem until they are bottomed in the stem hole;
4. Put packing protector (11B) and packing gland sleeve (15) onto the stem on top of the packing set.
5. Install the Belleville washers, tab washer and nut onto the stem hand tight.
6. Turn the stem until the upper stem flat is perpendicular to the valve centerline (closed, so that the ball can fit onto the stem):
7. Install the ball (3) inside the valve body. The lower stem flats will fit into the slot on top of the ball;
8. Turn the stem so that the ball is in the open position (the ball will not fall out of the valve);
9. Install the seats (4) and body seals into the body ends. Make sure the spherical curvature side of the seat will face the ball;
10. Lift the valve into position between the flanges in the pipeline.
11. Install the end cap bolts (9), lock washers (7) and nuts (8). Cross tighten all nuts to the values indicated in Table 1.
12. (Note: The use of a bore alignment tool, about 1.0 mm (0.04 inch) less than the internal diameter of the end cap and ball, inserted through the end cap and ball will prevent the ball from turning as the stem gland nut is tightened on the stem.
13. The bore alignment tool should be made from a material softer than 300 Series S.S. so that it will not inadvertently scratch the valve end cap or ball. Suggested materials: aluminum T6061. Acetal or other suitable hard polymer/plastic material.)
14. Secure the tab washer with one ear bending up; Place the handle (25) onto the stem, on top of the stem gland nut (26);
15. Secure the handle (25) with the remaining stem lock nut (26).
16. Cycle the valve slowly several times. By cycling slowly, the seats will align with and conform to the ball. A fast turning motion initially may damage the seats before they have a chance to form the proper seal:

3"&4" VALVE RE-ASSEMBLY PROCEDURES: (refer to page 7)

1. Hold the body horizontally in a vise firmly enough so it will not move but do not crush it.
2. Install bearing sleeve (13), washer protector (11A) and thrust washer (12) on valve stem (5) and slide the stem into the stem hole in valve body (1):
3. Slide the stem packing (14) onto the stem until it is seated in the bottom of the stem hole;
4. Put packing protector (11B), then packing gland sleeve (15) on top of the stem packing;
5. Install packing gland (16) and bolts (17). Lightly tighten to secure packing gland.
6. Install stop housing (20) and housing bolts (21) hand



- tight. Install travel stop (22) and snap ring (30):
7. Rotate the stem to the closed position (the upper stem flat is perpendicular to the port centerline) and install the ball (3) inside the valve body. The lower stem flats will fit into the slot on top of the ball;
 8. Turn the stem so that the ball is in the open position the upper stem flat is parallel to the bore centerline. The ball will not fall out of the valve;
 9. Install the seats (4) and body seals (6) into the body ends. Make sure the spherical curvature side of the seat will face the ball;
 10. Lift the valve into position between the flanges in the pipeline.
 11. Install the end cap bolts (9), lock washers (7) and nuts (8). Cross tighten all nuts to the values indicated in Table 1.
 12. Secure the handle (25A) with the handle bolt (27).
 13. Cycle the valve slowly several times. By cycling slowly, the seats will align with and conform to the ball. A fast turning motion initially may damage the seats before they have a chance to form the proper seal:

**6"-12" VALVE RE-ASSEMBLY PROCEDURES:
(refer to page 8)**

1. Hold the body horizontally in a vise firmly enough so it will not move but do not crush it.
2. Install bearing sleeve (13), washer protector (11A) and thrust washer (12) on valve stem (5) and slide the stem into the stem hole on valve body (1):
3. Slide the stem packing (14) onto the stem until it is seated against the bottom of the stem hole;
4. Put packing protector (11B), then packing gland sleeve (15) onto the stem, on top of the stem packing;

5. Install packing gland (16) and bolts (17). Lightly tighten to secure packing gland.
6. Install stop housing (20) and housing bolts (21) hand tight. Install travel stop (22) and snap ring (30):
7. Rotate the stem to the closed position (the upper stem flat is perpendicular to the port centerline) and install the ball (3) inside the valve body. The lower stem flats will fit into the slot on top of the ball;
8. Turn the stem so that the ball is in the open position the upper stem flat is parallel to the bore centerline. The ball will not fall out of the valve.
9. Install the seats (4A), seat support rings (4B) and body seals (6) into the body ends. Make sure the spherical curvature side of the seat faces the ball;
10. Lift the valve into position between the flanges in the pipeline.
11. Install the end cap screws (9) and lock washers (7). Cross tighten the screws to the values indicated in Table 1.
12. Install the handle junction head (25B) onto the valve stem. Secure in place with one of the setscrews provided (27A).
13. Secure the handle (25) with the remaining setscrew (27).
14. Cycle the valve slowly several times. The seats will align with and conform to the ball. A fast turning motion initially may damage the seats before they have a chance to form the proper seal:

Refer to the instructions given in section 2, above, to re-commission the valve after installation.

For automated installations, follow the instructions provided with actuation instrumentation to correctly set up and recalibrate the installation.

Table 1 - Tightening torques for end cap nuts

VALVE SIZE	1/2"	3/4"	1"	1 -1/4"	1-1/2"	2"	3"	4"	6"	8"	10"	12"
Nut Torque (lb-in)	130	130	130	200	200	200	530					
(Lb-ft)							44	83	83	83	150	240



COMPONENTS

Item	Name
1	Body
2	End Cap
3	Ball
4	Seat
5	Stem
6	Body Seal
7	Washer
8	Body Nut
9	Body Bolt / Stud
12	Thrust Washer
14	Stem Packing
15	Gland Nut
19	Handle Washer
23	Stop Set Sleeve
24	Stop Bolt
25	Handle
26	Handle Nut
28	Handle Sleeve
29	Locking Device

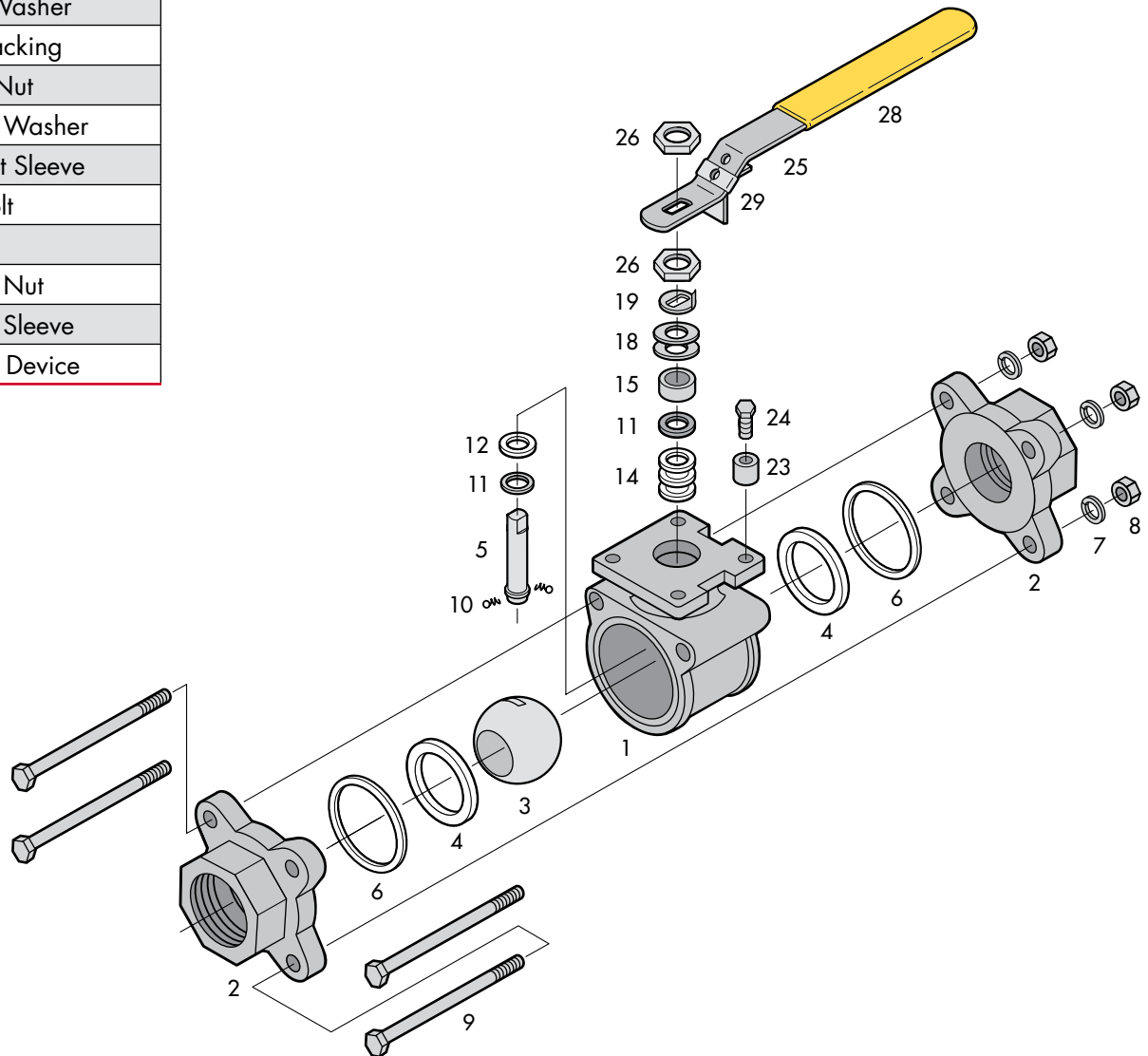



COMPONENTS

Item	Name
1	Body
2	END CAP
3	BALL
4	SEAT
5	STEM
6*	BODY GASKET
7	LOCKWASHER
8	NUT
9	BODY SCREW
10	ANT-STATIC
11A*	WASHER PROTECTOR
11B*	PACKING PROTECTOR
12	THRUST WASHER
13	BEARING SLEEVE
14*	STEM PACKING
15	PACKING GLAND SLEEVE
16	PACKING GLAND
17	GLAND BOLT
20	STOP HOUSING
21	HOUSING BOLT
22	TRAVEL STOP
25A	LEVER
27	HANDLE BOLT
30	SNAP RING

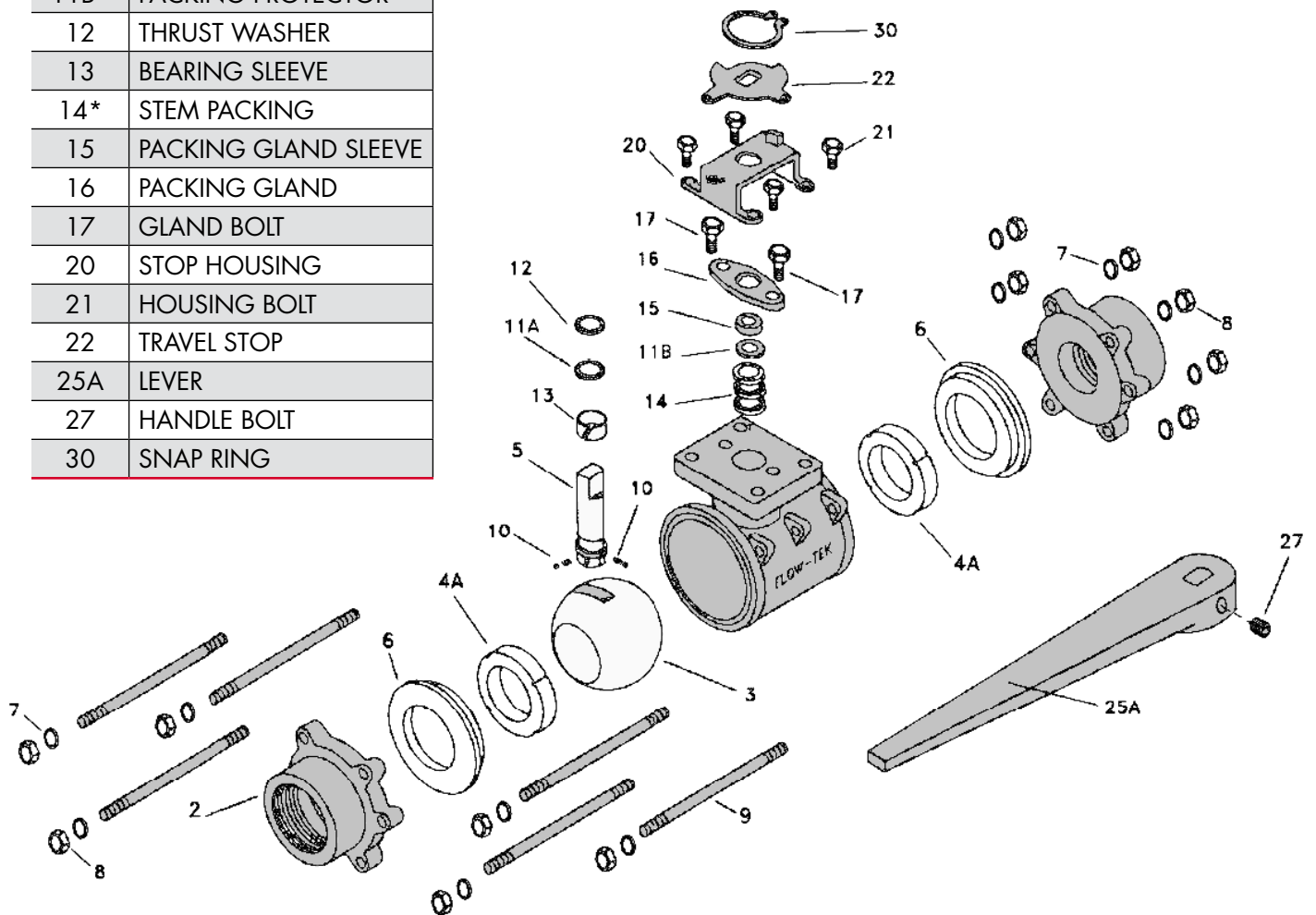



COMPONENTS

Item	Name
1	BODY
2	END CAP
3	BALL
4A	SEAT
4B	SEAT SUPPORT
5	STEM
6*	BODY GASKET
9	BODY SCREW
10	ANT-STATIC
11A*	WASHER PROTECTOR
11B*	PACKING PROTECTOR
12	THRUST WASHER
13	BEARING SLEEVE *
14*	STEM PACKING
15	PACKING GLAND SLEEVE
16	PACKING GLAND
17	GLAND BOLTS
20	HOUSING
21	HOUSING SCREWS
22	TRAVEL STOP
25A	LEVER
25B	HANDLE JUCTION HEAD
27	HANDLE BOLT
30	SNAP RING

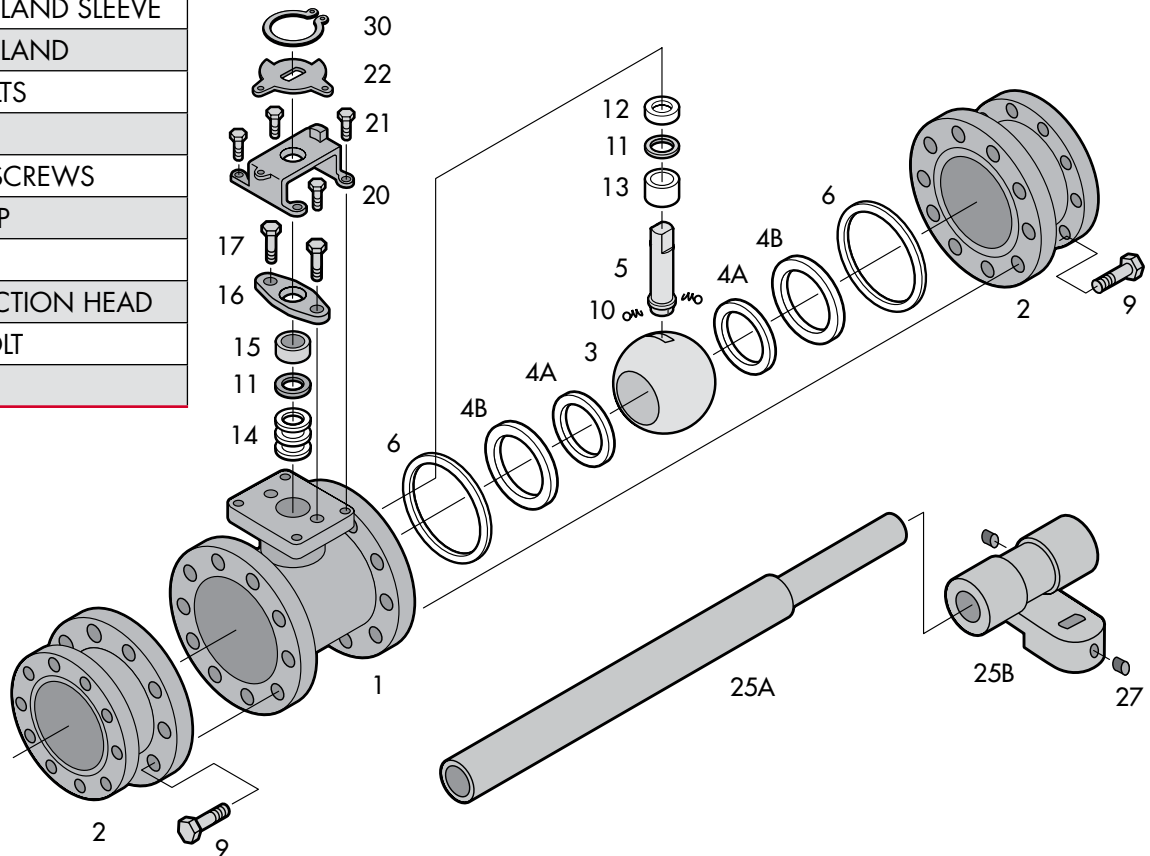



8. Short and Long Term Storage:

Short term:

1. Short term storage is defined as storage of products and equipment to be used in the construction of a project for periods of one to three months.
2. Ball valves should remain in the original shipping containers be placed on pallets of wood or other suitable materials. End protectors should remain on the valve ends to prevent the entrance of dirt.
3. Valves should be stored in the open position to protect the ball and seats.
4. Storage of ball valves can be in an open uncovered area provided provisions are made for inclement weather such as tarps or sheeting. Valves with electric actuators shall be stored under cover until ready for installation.

Long term:

1. Long term storage is storage of products and/or equipment for periods of three months or more.
2. Valves should be stored in the open position to protect the ball and seats.
3. Ball valves should remain in the original shipping containers placed on pallets of wood or other suitable materials and stored indoors. End protectors should remain on the valve ends to prevent the entrance of dirt.

The storage environment should be dry and not have severe swings in temperature and humidity.

9. Safety Summary

1. Read completely and understand all instructions provided prior to beginning installation or maintenance.
2. Follow all instructions as described using the correct tools for the job.
3. Before installing this equipment, confirm that it is suitable for the intended service.

The identifications tags describe the maximum allowable service conditions for this product.

4. Be sure that the installation is protected by appropriate pressure control and safety devices to ensure that acceptable limits are not exceeded.
5. Remove actuation air and power connections and confirm that there is no stored energy in the actuation such as compressed springs or trapped air before beginning. Stored energy devices can cause serious injury if the energy is released without warning.
6. Confirm that line pressure has been removed and that there is no pressure trapped within the valve prior to beginning service. Do not attempt to remove any packing components or other fittings before confirming that pressure has been completely removed!
7. Do not begin service work without proper tools and protective safety measures.
8. The work area should be clear of obstructions and other safety hazards.